

Cross Beam Jib (CBJ)

The Cross Beam Jib offers the flexibility to handle loads via a traditional jib method or via a spreader beam all in one attachment. Simply remove the retaining pin from the beam and slide into the desired position, then replace the pin, ensuring the beam is locked in that position. Then simply drive slowly forwards until the truck forks are located in the attachment sleeves and simply use the retaining chain to fix the attachment to the forklift. Then lifting can occur.

Cross Beam Jibs gives dual functions of supporting a load along the truck length like a traditional jib or lifting beam, yet also the option to handle loads at right angles to the truck like a spreader beam. The attachment is fork mounted and secured to the truck using a chain that is wrapped around the carriage of the truck. When in the jib mode the beam reached 2000mm with a SWL of 500kgs, in the spreader beam mode the beam spans 2000mm, with a minimum load centre of 250mm, and an SWL of 2000kgs.

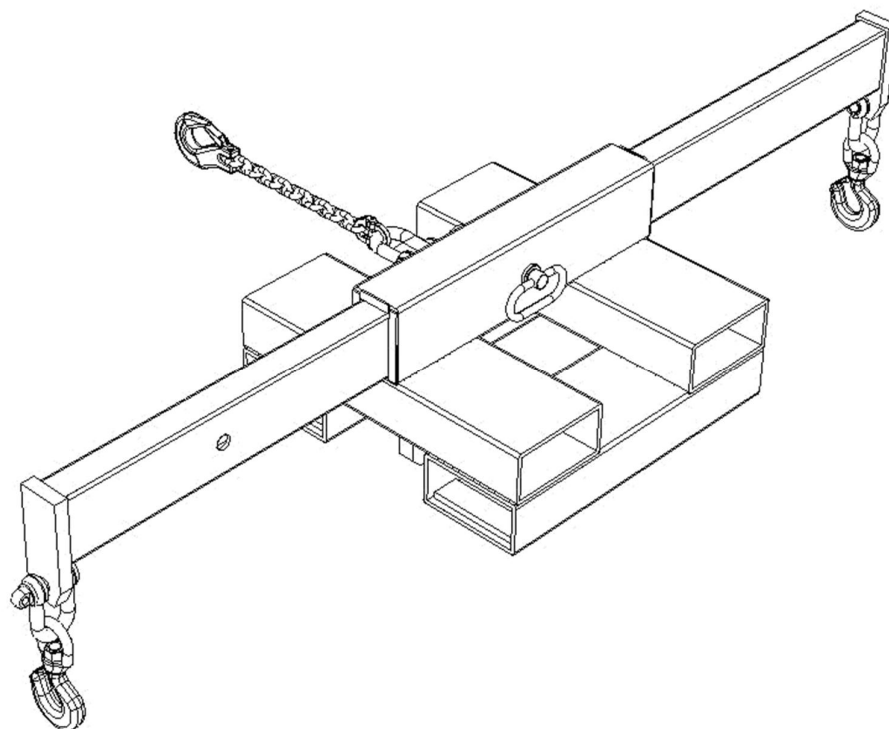

Model Ref.	Load Ctr Jib Mode	Load Ctr Beam Mode	Capacity Jib Mode	Capacity Beam Mode	Weight
CBJ 250-2000	2000mm	250mm	500kgs	2000kgs	125kgs