



# Fork Mounted Drum Rotator (DTR)

CONTACT Fork Mounted Drum Rotators are designed for manual rotation of 210 litre drums. The attachment simply slides onto the truck forks, thus allowing 360 degree controlled pouring/rotation via the gearbox. Variations of girdle types are available to suit steel or plastic drums; there is also a model to suit smaller 110 litre drums

Our best selling Fork Mounted Drum Rotator offers controlled, safe pouring of 210litre stell/plastic drums. In order to pick up a drum; set the girdle to its horizontal position by using the handle/chain loop fitted to the gearbox. The truck forks must then be positioned at a height such that the girdle fits around the centre of the drum, between its rolling hoops.. Ensure that the drum is held securely before lifting. Once lifted the drum can be rotated to begin pouring, the gearbox design ensures the drum can be locked at any desired angle.

Heavy Duty models available upon request to suit upto 1000kgs drums.

Hydraulic gearbox option also available upon request (DTR-1-H)

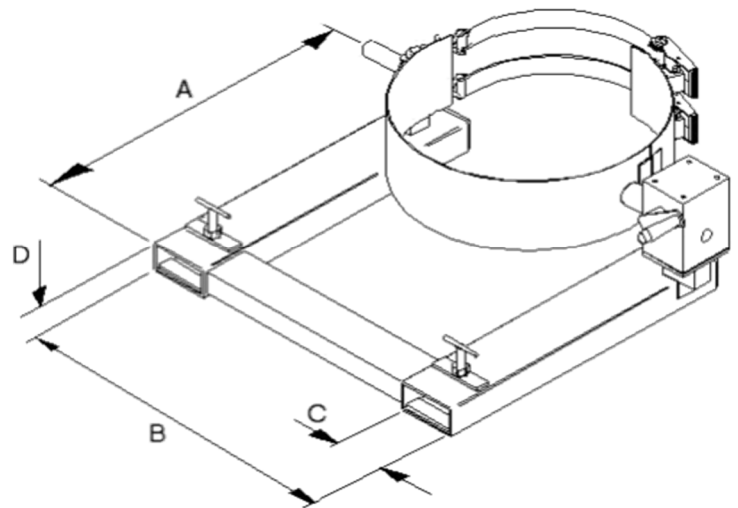

Model	Weight	C of G
DTR-1	90kgs	510mm
DTR-2	96kgs	510mm
DTR-1-H	115kgs	650mm

Model	Capacity	No of Drums	Type of Operation	Drum Types	"A" Load Ctr	"B" Fork Spread	"C" Fork Width	"D" Fork Thickness
DTR-1	360kgs	1	Crank Handle	1 & 2	750mm	942mm	140mm	50mm
DTR-2	360kgs	1	Loop Chain	1 & 2	750mm	942mm	140mm	50mm
DTR-1-H	360	1	Hydraulic	1 & 2	750mm	942mm	140mm	50mm