

# Carriage Mounted Drum Handler (CDH)

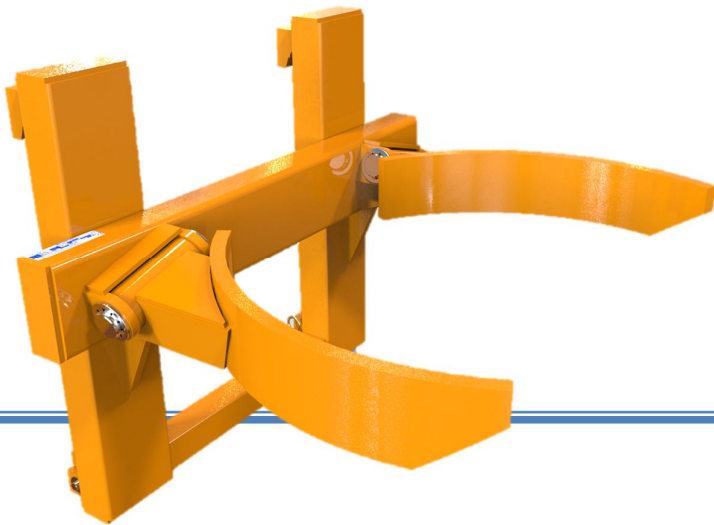

Carriage Mounted Drum Handlers are designed for use with 210/220 litre (45 gallon) steel drums, with rolling hoops. This attachment fits directly onto the carriage in place of the forks and is the ideal choice if a dedicated truck is required to handle drums or if turning room is restricted.

The Carriage Mounted Drum Handler is fully automatic and has two curved arms which hinge at one end.

To lift a drum, approach it with the clamp arms horizontal and positioned between two rolling hoops.

When the arms contact the drum they will open automatically, falling back around the drum as you proceed forwards. When the attachment is raised the arms will grip the drum tightly under the upper rolling hoop.

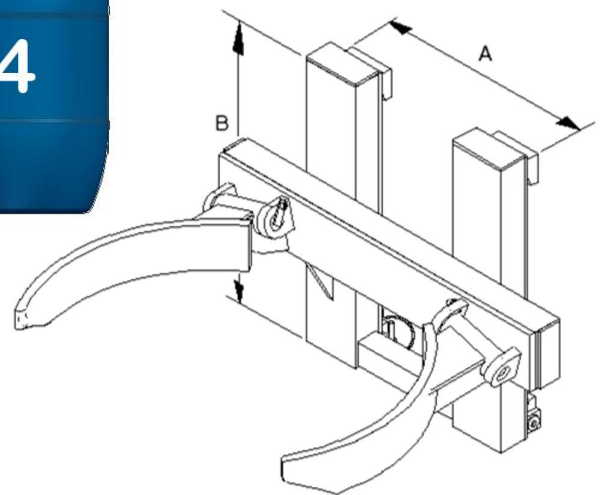

Model Ref.	Weight	C of G	LLC
CDH-1	40kgs	114mm	190mm
CDH-1-HD	49kgs	121mm	200mm
CDH-2	59kgs	122mm	190mm

Model Ref.	Capacity	Carriage CIs	No. of Drums	Drum Types	"A"	"B"
CDH-1	500kgs	2	1	1	400mm	500mm
CDH-1-HD	1000kgs	2	1	1	400mm	500mm
CDH-2	1000kgs	2	2	1	400mm	500mm