

TELEHANDLER CONCRETE SKIP

With fork pockets and lifting points



Presentation: This concrete skip has been specially designed for the loading under a concrete mixer (low loading height = 730 mm). The skip is fitted with a 1 meter long hose.

Gate operation: By lever or directly on the gate. The lever is adjustable in front or rear.

Means of handling: This skip is fitted with 2 way fork pockets with safety locking system to be handled by a telehandler. The skip can also be handled with a crane thanks to its lifting points

BSB skip filled from a site concrete mixer



BSB skip fitted with a 1 meter long hose



Safety locking system



Lever in rear position



Levier en position avant

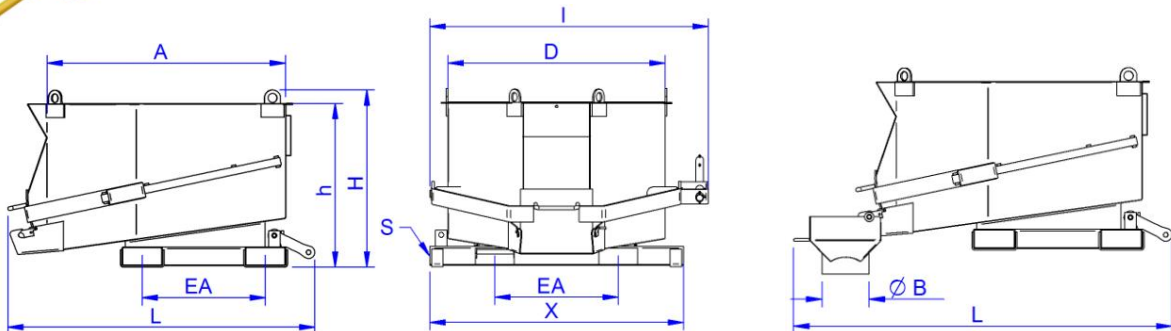

Product code	Designation	Capacity (in Litres)	SWL (kg)	A (mm)	ØB (mm)	D (mm)	EA (mm)	h (mm)	S (mm)	X (mm)	L x l x H (mm)	Net weight (in Kg)
09051	BSB 500 with funnel (hose length 1m Ø200)	500	1200	1041	200	944	540	713	170x75	1110	1610 x 1218 x 771	155
09000050901	Funnel Option for BSB with hose length 1m Ø200											5
09000050902	Funnel Option for BSB with hose length 1m Ø90											5
09000050903	Funnel Option for BSB with hose length 1m Ø150											5
09000050904	Funnel Option for BSB with hose length 1m Ø250											5

(Other capacities on request)

These technical details are given for information purposes only, they can be changed without any notice.