



Drum Rotator Crane Slung (DTR)

Our popular Crane Slung Drum Rotator is designed to offer controlled pouring and transport of drums. In order to pick up a drum, set the girdle to its horizontal position by using the handle or chain fitted to the geared turning box./gearbox. The lifting yoke must then be positioned at a height such that the girdle fits between the drums centre most rolling hoops. Once securely fastened the drum can be lifted to pouring height and rotation can commence again by means of the handle or chain fitted to the gearbox. The gearbox will lock the drum at any angle during tipping.

CONTACT Crane Slung Drum Rotators are designed for controlled manual rotation of 210 litre drums, the attachment is slung under a crane, small fork pockets are fitted for use with a forklift truck. The gearbox allows controlled pouring and rotation through a full 360 degrees. Variations of girdle types are available to suit either steel or plastic drums. There is also a model for heavier drums of powder, scrap etc. As well as a model to suit 110 litre drums.



Model Ref.	Capacity	No. Of Drums	Drum Type	Type of Operation	"A" Load Centre	"B" Fork Spread	"C" Fork Spread	"D" Fork Thickness
DTR-3-SC	360kgs	1	1	Crank Handle	818mm	707mm	140mm	60mm
DTR-4-SC	360kgs	1	1	Loop Chain	818mm	707mm	140mm	60mm
DTR-3-DS	360kgs	1	1 & 2	Crank Handle	818mm	707mm	140mm	60mm
DTR-4-DS	360kgs	1	1 & 2	Loop Chain	818mm	707mm	140mm	60mm
DTR-3-110	200kgs	1	1	Crank Handle	688mm	547mm	140mm	60mm
DTR-4-110	200kgs	1	1	Loop Chain	688mm	547mm	140mm	60mm

Model Ref.	Weight	C of G
DTR-3-SC	90kgs	50mm
DTR-4-SC	96kgs	50mm
DTR-3-DS	92kgs	50mm
DTR-4-DS	98kgs	50mm
DTR-3-110	85kgs	50mm
DTR-4-110	90kgs	50mm

Ordering Information

Truck Capacity

Fork Width/Thickness

Drum Weight

Drum Type

Max Fork Spread

Drum Diameter

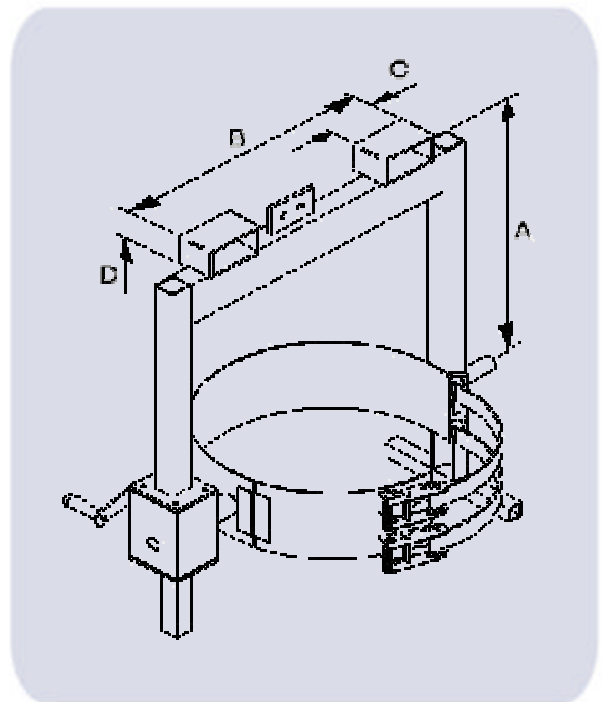
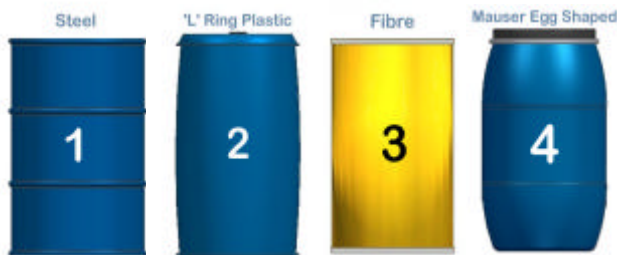

Product Video Available @ www.forklift-attachments.co.uk

For further information contact us on: **01686 611 200**

Or visit us at: www.forklift-attachments.co.uk