

Carriage Mounted Big Bag Tines (CBBT)

With the lower hangers removed and the poles resting on a raised surface, drive the fork truck slowly forwards until the top of the truck carriage plate contacts the backplate of the attachment just below the top hangers. Carefully raise the mast until the centralising lug on the attachment castellation on the carriage plate and the top hangers fit snugly on the top of the carriage rail. The bottom hangers must then be bolted in position through the holes provided.

CONTACT Carriage Mounted Bag Tines are designed for handling standard "big bags", this carriage mounted attachment gives increased lift height, the tines being set at the top of the carriage plate. The bags are picked up by pushing a tine through the loops on each corner of the big bag. Handler stops prevent the bag from sliding forwards during transport.



Model Ref.	Capacity	Carriage Cls	Weight	LLC	C Of G
CBBT-1	1000kgs	2	150kgs	80mm	300mm
CBBT-2	1000kgs	3	155kgs	80mm	250mm

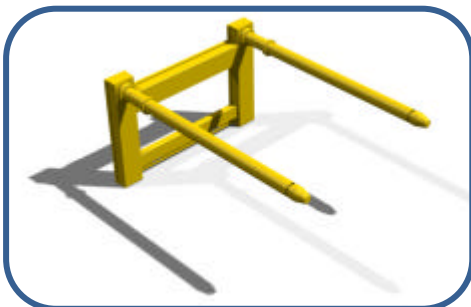

Ordering Information:

- ✓ Truck Capacity
- ✓ Carriage Class
- ✓ Bag Type & Size
- ✓ Bag Weight

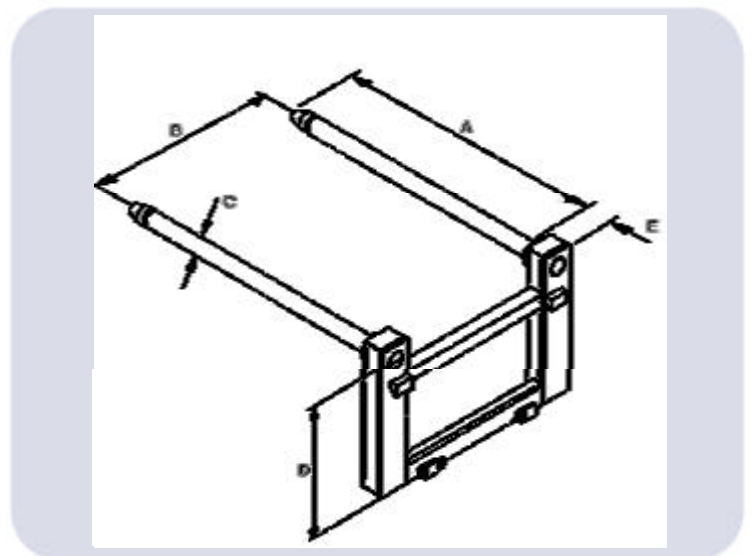

Model Ref.	"A" Pole Length	"B" Pole Ctrs	"C" Pole Dia	"D" Pole Ctr from Carriage
CBBT-1	1220mm	830mm	70mm	547mm
CBBT-2	1220mm	830mm	70mm	547mm